

Illustrated Parts List	1992-08
	19202001

GT 180

(H1850C), 954000372

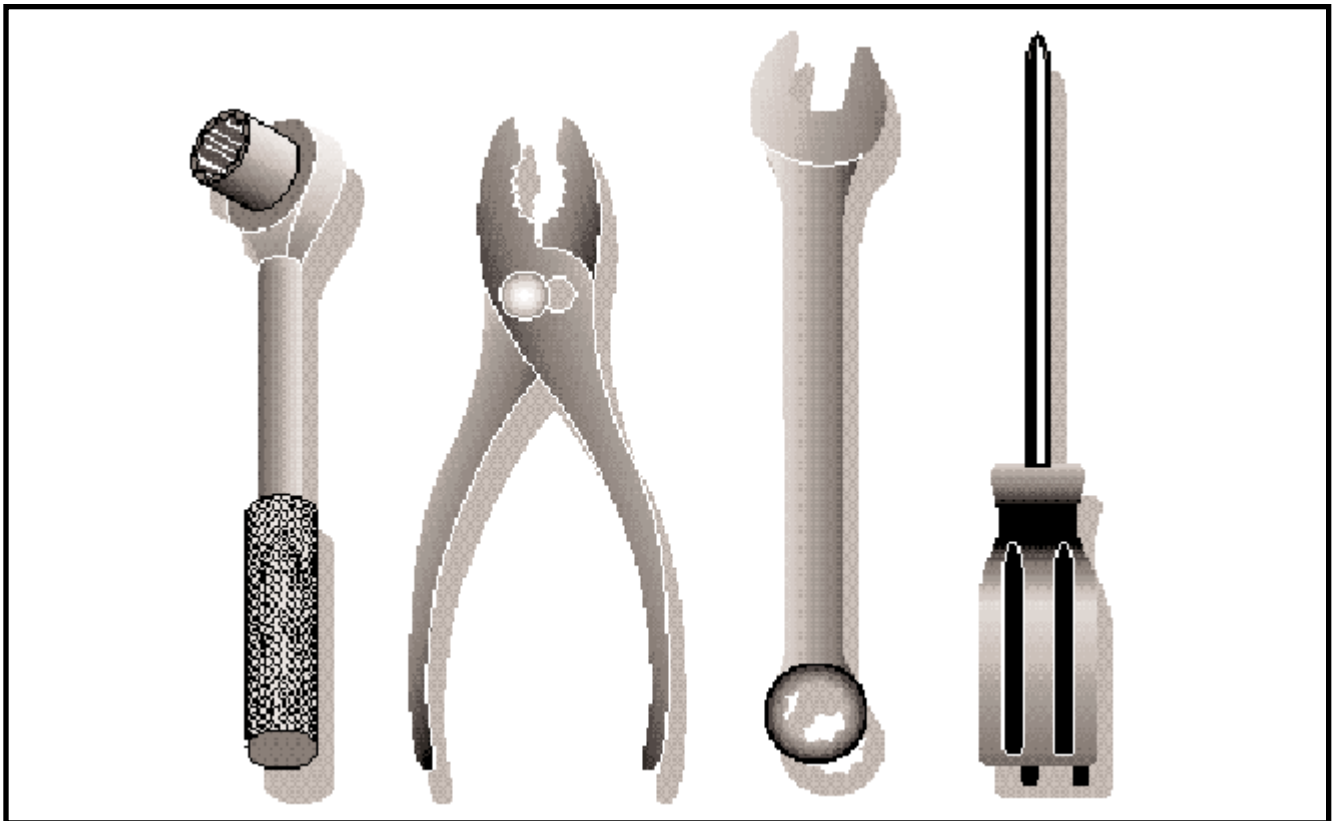

Repair Parts Manual

Ride Mower

REPAIR PARTS

18 HP 50" TRACTOR - - MODEL NO. GT180 (H1850C), PRODUCT NO. 954 00 03-72
ELECTRICAL

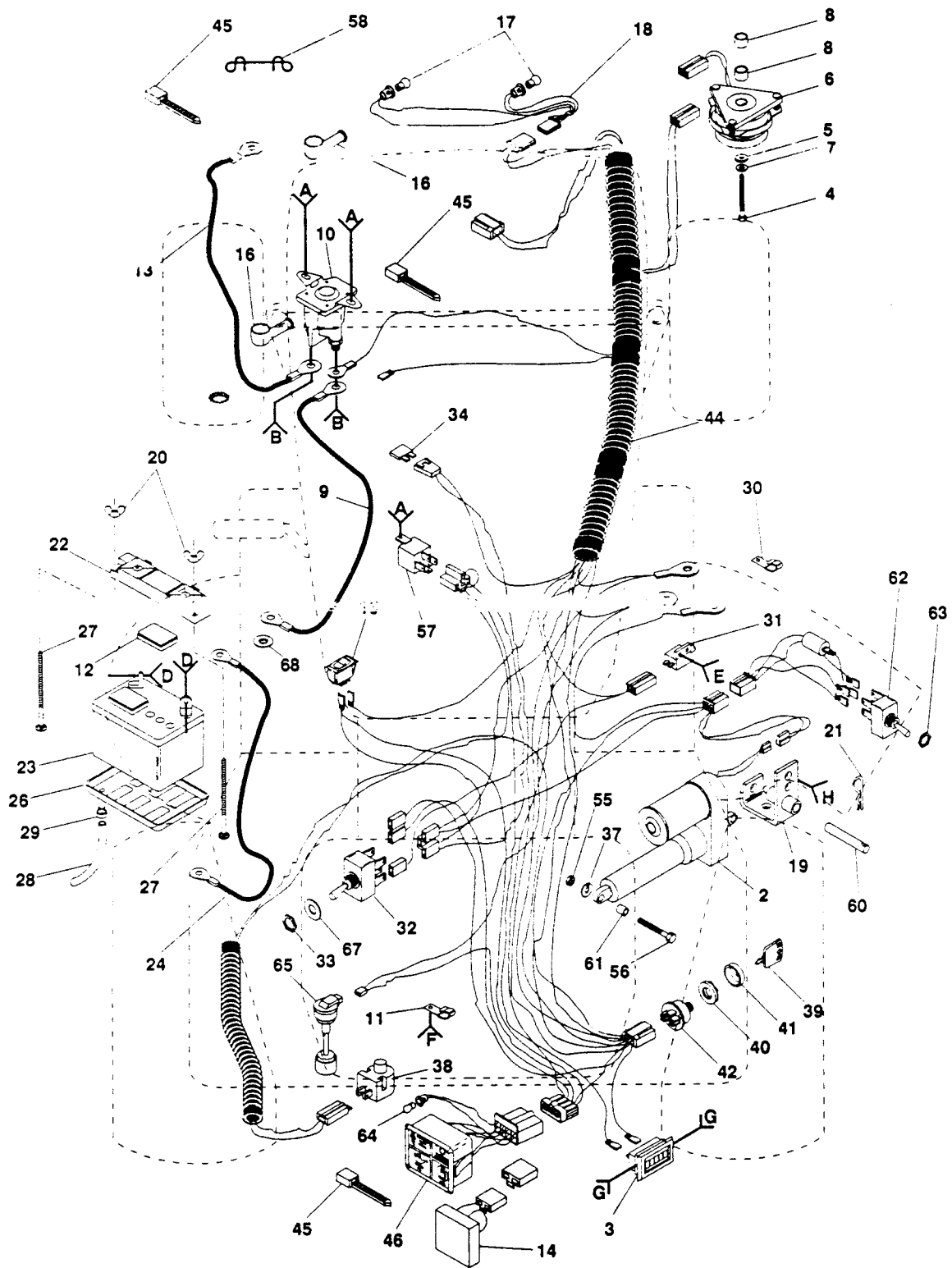

- | | | | | | | | |
|----------|----------|----------|----------|----------|----------|----------|----------|
| A | B | C | D | E | F | G | H |
| | | | | | | | |
| | | | | | | | |
| | | | | | | | |
| | | | | | | | |

REPAIR PARTS

18 HP 50" TRACTOR - - MODEL NO. GT180 (H1850C), PRODUCT NO. 954 00 03-72

ELECTRICAL

KEY NO.	PART NO.	DESCRIPTION	KEY NO.	PART NO.	DESCRIPTION
1	817011008	Screw #10-24 x 1/2	35	873951000	Nut, Keps #10-32
2	532124371	Actuator, Electric	36	872110608	Bolt, Carriage 3/8-16 x 1
3	532110940	Meter, Hour	37	810040600	Washer, Lock 3/8
4	871130724	Bolt, Hex 7/16-20 x 1-1/2 Gr. 8	38	532121305	Switch, Seat
5	532126197	Washer	39	532122147	Key
6	532109550	Clutch, Electric	40	532124211	Nut, Ignition
7	810040700	Washer, Lock 7/16	41	532123620	Bezel, Ignition
8	532106367	Spacer, Clutch	42	532125104	Switch, Ignition
9	532124770	Cable, Battery	43	874641008	Screw, Slot, Pan HD #10-32 x 1/2
10	532109081	Solenoid	44	532137465	Harness, Ignition
11	532004171	Clip, Insulated	45	532124756	Cable Tie
12	532121264	Battery Caps	46	532126519	Light Package
13	532129458	Cable, Starter	47	810090400	Washer, Lock 1/4
14	532127385	Sensor, Low Voltage	48	873350400	Nut, Hex Jam 1/4-20
15	532110712	Switch, Light	49	817190408	Screw, Hex Washer Hd. Cutting 1/4-20 x 1/2
16	532131563	Cover, Terminal	50	874760412	Bolt, Hex Hd. 1/4-20 x 3/4
17	532124893	Bulb, Light	51	819091016	Washer 9/32 x 5/8 x 16 Gauge
18	532136849	Harness, Light Socket	52	810040400	Washer, Lock 1/4
19	532124867	Bracket Assembly, Actuator	53	873220400	Nut, Hex 1/4-20
20	532123198	Nut, Wing 1/4-20	54	871031008	Screw, Hex Washer Hd. #10-32 x 1-1/2
21	532004940	Spring, Retainer	55	873220600	Nut, Fin Hex 3/8-16
22	532102476	Guard, Terminal	56	874520636	Bolt, Fin Hex 3/8-16 x 2-1/4
23	532121537	Battery	57	532109748	Assembly, Relay
24	532124773	Cable Ground	60	532007085	Pin, Actuator
26	532124886	Tray, Battery	61	532005950	Tube
27	872240460	Bolt, Carriage 1/4-20 x 7-1/2	62	532126289	Switch Assembly, Lift
28	532100541	Tube, Plastic	63	532007319	Washer, Lock
29	532109596	Clamp, Hose	64	532110143	Bulb, Dashboard, Light
30	532100207	Clip	65	532126487	Sensor, Low Fuel
31	532104445	Switch, Interlock	66	811050600	Washer, Lock, External Tooth
32	532126018	Switch, P.T.O.	67	819171216	Washer 17/32 x 3/4 x 16 Ga.
33	532124932	Nut, Hex	68	811150400	Washer, Lock, Int. tooth 1/4
34	532108824	Fuse			

NOTE: All component dimensions given in U.S. inches.
1 inch = 25.4 mm

REPAIR PARTS

18 HP 50" TRACTOR -- MODEL NO. GT180 (H1850C), PRODUCT NO. 954 00 03-72

FRAME, FENDER AND DRAWBAR

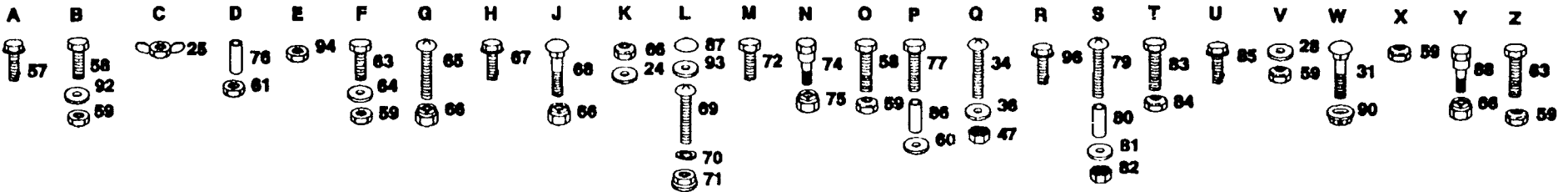
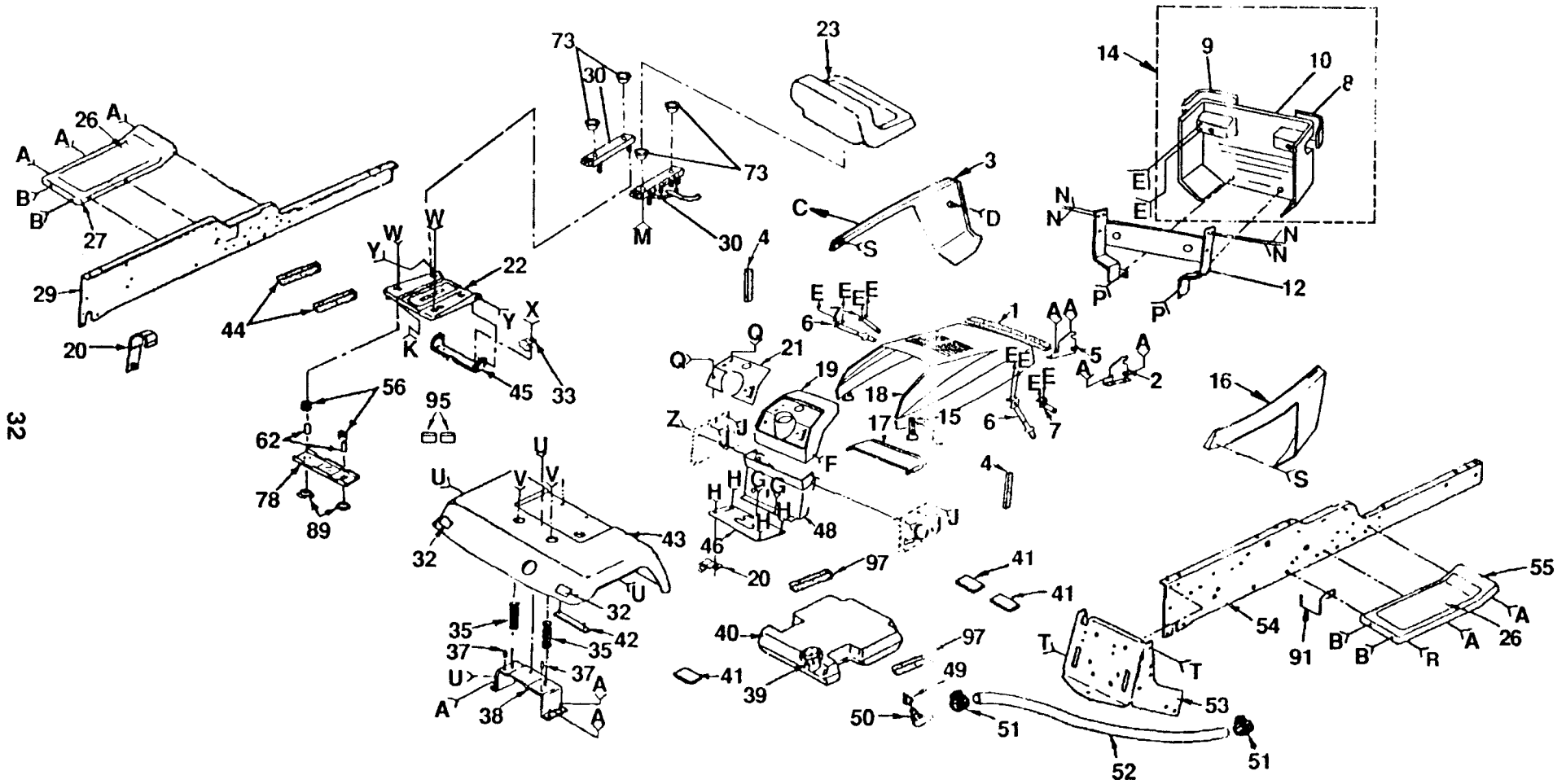

REPAIR PARTS

18 HP 50"TRACTOR - - MODEL NO. GT180 (H1850C), PRODUCT NO. 954 00 03-72

FRAME, FENDER AND DRAWBAR

33

KEY NO.	PART NO.	DESCRIPTION	KEY NO.	PART NO.	DESCRIPTION	KEY NO.	PART NO.	DESCRIPTION
1	532109458	Strip, Foam	33	532124955	Clip, Insulated	67	817720408	Screw, Hex Washer Thrd. Cutting 1/4-20 x 1/2
2	532110853	Frame, Pivot, Ass'y, Bracket, R.H.	34	874180512	Screw, Mach. Hd. 5/16-18 x3/4	68	872140506	Bolt, Carriage 5/16-18 x 3/4
3	532125389	Panel, Side, L.H.	35	532124181	Spring, Compression	69	874191008	Screw, Cr. Pan. Mach. #10-24x1/2
4	532106088	Strip, Foam	36	819111116	Washer 11/32 x 11/16 x 16 Gauge	70	810071000	Washer, Lock #10
5	532110852	Frame, Pivot, Ass'y, Bracket, L.H.	37	532105531	Nut, Push	71	532125004	Nut, Weld
6	532106784	Strap Assembly, Hinge, Rear	38	532105509	Bracket, Fender	72	817190516	Screw, Hex 5/16-18 x 1
7	532104618	Strap Assembly, Hinge, Front	39	532123549	Cap, Fuel	73	532124427	Spacer
8	532124251	Lens, R.H.	40	532127383	Tank, Fuel /sensor	74	532123481	Bolt, Shoulder 1/4-20
9	532124250	Lens, L.H.	41	532106082	Pad, Spacer	75	873680400	Nut, Crownlock 1/4-20
10	532127325	Grill	42	532105511	Strap, Fender	76	532001260	Spacer
12	532124574	Support, Grill	43	532124927	Fender	77	874760440	Bolt, Fin Hex 1/4-20 x 2-1/2
14	532127320	Grill, Assembly (Includes Keys 8, 9, and 10)	44	532121251	Foam, Strip	78	532121246	Bracket, Switch Mount
15	532109808	Latch, Hood	45	532126656	Bracket, Pivot, Seat	79	874981020	Screw, Mach Cr. Pan #10-24 x 1-1/4
16	532125390	Panel, Side, R.H.	46	532124837	Cover, Shift, Gate	80	532007206	Spacer, Split #10 x 3/4
17	532007985	Support, Battery	47	873510500	Nut, Keps 5/16-18	81	819070818	Washer 7/32 x 1/2 x 18 Gauge
18	532125007	Hood	48	532104608	Dash Assembly	82	873731000	Nut, Keps #10-24
19	532124182	Dashboard	49	532124952	Bushing	83	874760716	Bolt, Hex 7/16-14 x 1
20	532004171	Clip, Insulated	50	532124951	Stem, Tank Fuel	84	873680700	Locknut 7/16-14
21	532124772	Dashplate	51	532123487	Clamp, Hose	85	817490608	Screw, Hex Washer Thread Rolling 3/8 x 16 x 1/2
22	532131451	Pan, Seat	52	532124703	Fuel Line	86	532121235	Spacer
23	532124187	Seat	53	532007982	Drawbar	87	532110356	Cap, Snap
24	819111610	Washer 11/32 x 1 x 10 Gauge	54	532110892	Rail, Frame, R.H.	88	532105529	Bolt, Shoulder
25	532123198	Nut Wing 1/4-20	55	532124914	Footrest, R.H.	89	532121248	Bushing, Snap
26	532108256	Pad, Footrest	56	532123740	Spring, Compression	90	532123976	Nut, Flange Lock 1/4-20
27	532124899	Footrest, L.H.	57	817490612	Screw, Hex Washer Thread Rolling 3/8-16 x 3/4	91	532105500	Retainer, Belt, Lower
28	819131614	Washer 13/32 x 1 x 14 Gauge	58	874760612	Bolt, Hex 3/8-16x3/4	92	819131312	Washer 13/32 x 13/16 x 17 Gauge
29	532110893	Rail, Frame, L.H.	59	873680600	Locknut 3/8-16	93	532110357	Washer, Snap Cap
30	532124428	Slide, Seat Set	60	819091216	Washer 9/32 x 3/4 x 16 Ga.	94	873510400	Nut, Hex 1/4-20
31	872050411	Bolt, Carriage 1/4-20 x 1-3/8	61	873220400	Nut, Hex 1/4-20	95	532124238	Cap, Spring
32	532106202	Reflector, Taillight	62	532130481	Spacer, Split	96	817490616	Screw, Hex, Washer Thrdrol 3/8-16x1
			63	874760616	Bolt, Hex 3/8-16 x 1	97	532109227	Pad, Idler
			64	819131316	Washer 13/32 x 13/16 x 16 Gauge			
			65	874180512	Screw, Mach. Cr. Thrd. 5/16-18 x3/4			
			66	873680500	Nut, Crownlock 5/16-18			

NOTE: All component dimensions given in U.S. inches.
1 inch = 25.4 mm

REPAIR PARTS

18HP 50" TRACTOR - - MODEL NO. GT180 (H1850C), PRODUCT NO. 954 00 03-72
GROUND DRIVE

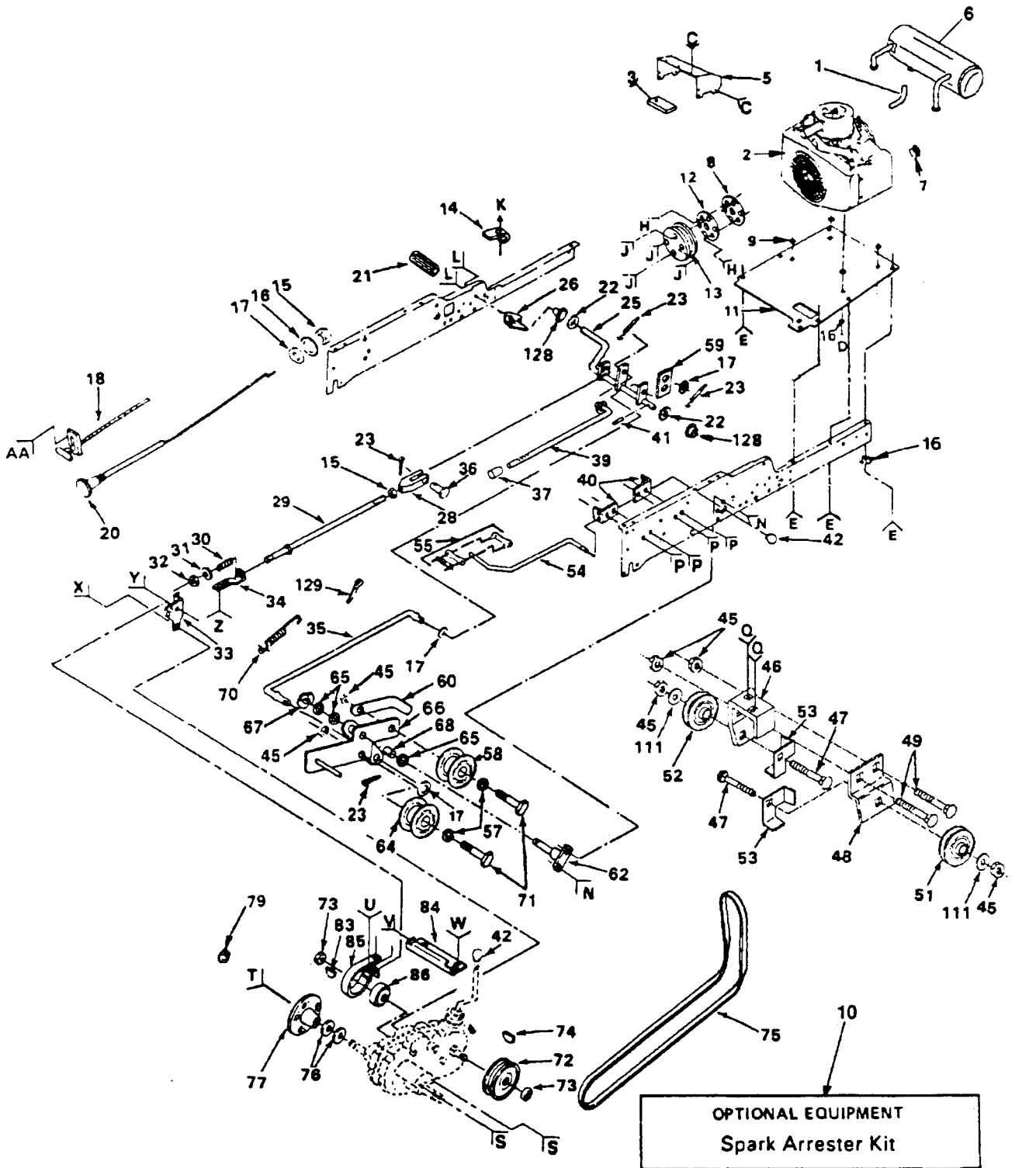

- | | | | | | | | | | | | | | | | | | | |
|---|----|-----|-----|-----|-----|-----|-----|-----|-----|-----|-----|-----|-----|-----|-----|-----|-----|-----|
| C | D | E | H | J | K | L | N | P | Q | S | T | U | V | W | X | Y | Z | AA |
| 4 | 98 | 100 | 101 | 102 | 103 | 105 | 101 | 128 | 107 | 114 | 118 | 117 | 119 | 119 | 124 | 121 | 109 | 122 |
| | 45 | 46 | 94 | | 104 | 86 | 45 | 110 | 45 | 118 | | 87 | 120 | 115 | 84 | | | |
| | | | | | | | | | | | | 118 | | 17 | | | | |

REPAIR PARTS

18HP 50" TRACTOR - - MODEL NO. GT180 (H1850C), PRODUCT NO. 954 00 03-72

GROUND DRIVE

KEY NO.	PART NO.	DESCRIPTION	KEY NO.	PART NO.	DESCRIPTION
1	532126086	Exhaust Tube Outlet	58	532104360	Idler, Flat
2	532124276	Engine-18HP Kohler M18QS Type 24644	59	532121358	Retainer, Spring
3	532126350	Duct, Lower Assembly	60	532121360	Retainer, Belt
4	817720408	Screw, Hex Thd. Cut 1/4-20x 1/2	62	532101358	Bracket Assembly, Clutch
5	532124508	Duct, Exhaust, Upper	64	532121361	Idler, Grooved
6	532124532	Muffler, Exhaust	65	532000207	Washer, Hardened
7	----	Plug, Oil Drain (Order from engine manufacturer)	66	532121356	Bracket, Clutch w//Bearing (Incl. Key No. 68)
8	532133692	Chaff Guard	67	812000039	Klip, Ring
9	532110869	Spacer	68	532105706	Bearing, Idler
10	532132922	Spark Arrester Kit	70	532121357	Spring, Extension
11	532110867	Base, Engine	71	874760628	Bolt, Hex 3/8-16x1-3/4
12	532104577	Adapter	72	532120332	Pulley, Transaxle
13	532121355	Pulley, Ground Drive	73	532009204	Locknut 1/2-20
14	532005304	Actuator, Switch, Interlock	74	532124708	Key, Woodruff 3/16x5/8
15	873610600	Nut, Hex 3/8-24	75	532110883	V-Belt
16	811050600	Washer, Lock Ext. Tooth 3/8	76	532007563	Washer, Thrust, Axle
17	819131316	Washer 13/32 x 13/16 x 16 Gauge	77	532135758	Bushing Assembly and Wheel Hub
18	532132746	Control, Throttle	79	812000034	Klip, Ring
20	532132780	Control, Choke	83	532125096	Key, Woodruff #9(3/16x3/4)
21	532123533	Cover, Pedal	84	532120404	Bracket, Support, Transaxle
22	532121749	Washer 25/32 x 1-1/4 x 16 Gauge	85	532101122	Band, Brake
23	876020312	Pin, Cotter 3/32 x 3/4	86	532000214	Drum, Brake
25	532104375	Shaft, Foot Pedal	89	873680400	Nut, Crownlock 1/4-20
26	532104601	Bracket, Interlock	94	810040600	Washer, Lock 3/8
28	532100604	Yoke	97	810040400	Washer, Lock 1/4
29	532005308	Rod, Brake	98	874780624	Bolt, Hex 3/8-16x1-3/4
30	532007241	Spring, Compression	100	874760612	Bolt, Hex 3/8-16x3/4
31	819131614	Washer 13/32 x 1 x 14 Gauge	101	874780616	Bolt, Hex Head 3/8-16 x 1 Grade 5
32	873530600	Locknut 3/8-24	102	817190516	Screw, Hex 5/16-18 x 1
33	532124692	Bracket, Brake	103	874321016	Screw, Fin #10-24 x 1
34	532124695	Guide, Rod, Brake	104	873631000	Locknut #10-24
35	532101356	Rod, Clutch	105	874760412	Bolt, Hex Head 1/4-20 x 3/4
36	532005102	Pin, Clevis	107	872140606	Bolt, Carriage 3/8-16 x 3/4 Grade 5
37	532071673	Cap, Plunger	109	872110506	Bolt, Carriage 5/16-18 x 3/4
39	532136284	Rod, Parking Brake	110	873680500	Locknut 5/16-18
40	532105598	Bracket, Rod, Shift	111	819131612	Washer 13/32 x 1 x 12 Gauge
41	532005142	Pin, Roll 3/16 x 1-1/4	114	874760720	Bolt, Hex 7/16-14 x 1-1/4
42	532121466	Knob	115	810040700	Washer, Lock 7/16
45	873680600	Locknut 3/8-16	116	532001304	Bolt, Hub
46	532121063	Bracket, V-Pulley, Drive, Mule	117	872140405	Bolt, Carriage 1/4-20 x 5/8
47	872110614	Bolt, Carriage 3/8-16 x 1-3/4	118	873220400	Nut, Hex 1/4-20
48	532122825	Bracket, Idler, Flat	119	874760716	Bolt, Hex 7/16-14 x 1
49	872140606	Bolt, Carriage 3/8-16 x 3/4	120	873680700	Nut, Crownlock 7/16-14
51	532102403	Idler, Flat	121	874370612	Screw, Mach. Undrcut. Flat Head 3/8-16 x 3/4
52	532101344	Pulley, Idler	122	532124949	Locknut 5/16-18
53	532122824	Keeper, Belt	123	817720410	Screw, Hex 1/4-20 x 1/2
54	532122253	Rod, Shift, Hi-Lo	124	874760614	Bolt, Hex 3/8-16 x 7/8
55	532122268	Connecting Link, Spring Clip	126	872140506	Bolt, Carriage 5/16-18 x 3/4
57	819131413	Washer 13/32 x 7/8 x 13 Gauge	128	532110895	Nyliner

NOTE: All component dimensions given in U.S. inches.
1 inch = 25.4 mm

REPAIR PARTS

18 HP 50" TRACTOR - - MODEL NO. GT180 (H1850C), PRODUCT NO. 954 00 03-72
STEERING

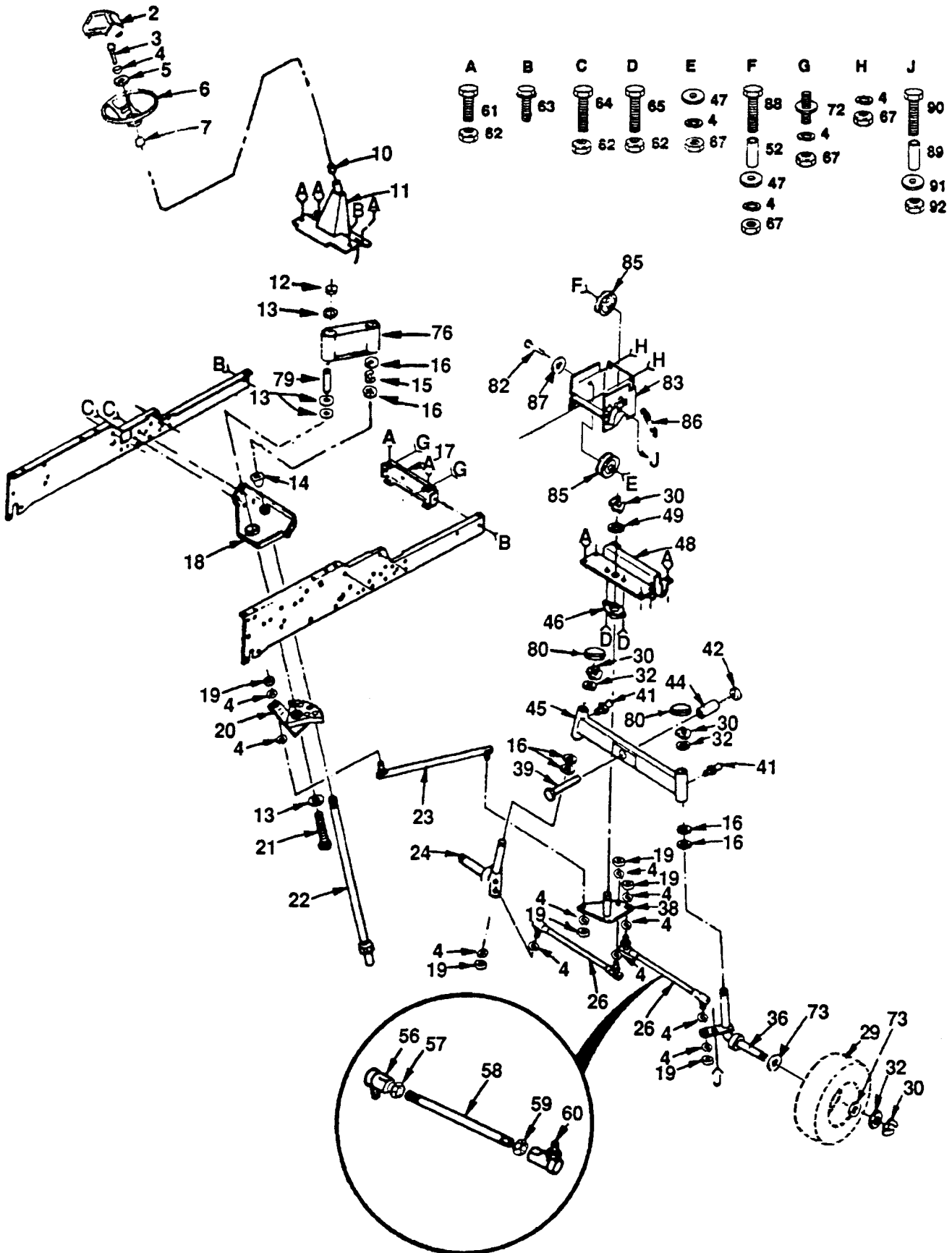

REPAIR PARTS

18 HP 50"TRACTOR - - MODEL NO. GT180 (H1850C), PRODUCT NO. 954 00 03-72

STEERING

KEY NO.	PART NO.	DESCRIPTION	KEY NO.	PART NO.	DESCRIPTION
2	532124416	Insert, Steering Wheel	46	532005292	Bushing, Bellcrank
3	874780616	Bolt, Hex 3/8-16 x 1 Grade 5	47	819131413	Washer 13/32 x 7/8 x 13 Gauge
4	810040600	Washer, Lock 3/8	48	532005284	Bracket, Axle
5	819133808	Washer 13/32 x 2-3/8 x 8 Gauge	49	819292016	Washer 29/32 x 1-1/4 x 16 Gauge
6	532124415	Wheel, Steering	52	532102933	Spacer, Split
7	532100711	Adapter, Steering	56	532121161	Joint, Tie Rod, L.H., Thread
10	532009038	Bearing	57	873700600	Nut Hex, Jam 3/8-24 L.H.
11	532101274	Support Assembly, Steering	58	532121162	Rod, Tie
12	873680800	Locknut 1/2-13	59	873360600	Nut, Hex, Jam 3/8-24
13	819172610	Washer 17/32 x 1-5/8 x 10 Gauge	60	532121160	Joint, Tie Rod, R.H., Thread
14	532104239	Bearing, Flanged	61	874760612	Bolt, Hex 3/8-16x3/4
15	812000034	Klip Ring	62	873680600	Locknut 3/8-16
16	532124931	Bearing, Thrust	63	817490612	Screw, Hex Wsh. Thdrol. 3/8-16 x 3/4
17	532005213	Bracket, Frame, Front	64	874780616	Bolt, Hex 3/8-16 x 1 Grade 5
18	532102439	Bracket, Support, Steering	65	874760616	Bolt, Hex 3/8-16x 1
19	873610600	Nut, Hex 3/8-24	67	873220600	Nut, Hex 3/8-16
20	532120424	Sector Assembly	72	532106615	Pin Mounting, Idler, Bracket
21	874780880	Bolt, Hex 1/2-13 x 5 Grade 5	73	532121749	Washer 25/32 x 1-1/4 x 16 Gauge
22	532104591	Shaft, Steering	76	532121177	Collar Weld Assembly
23	532110497	Link, Drag	79	532120199	Tube
24	532121168	Spindle, L.H.	80	532121232	Dust Cap Cover
26	532121159	Rod, Tie (Inc. Key #56-60)	82	874760632	Bolt, Hex 3/8-16 x 2
30	812000029	Klip Ring	83	532120542	Bracket, Idler
32	532121748	Washer 17/32 x 1-1/2 x 10 Gauge	85	532124858	Pulley, Idler
36	532121167	Spindle, R.H.	86	532007190	Spring
38	532108137	Bellcrank Assembly	87	819133808	Washer 13/32 x 2-3/8 x 8 Gauge
39	874781044	Bolt, Hex 5/8-11 x 2-3/4 Grade 5	88	874760636	Bolt, Hex 3/8-16 x 2-1/4
41	532124836	Fitting, Grease	89	532100644	Bushing, Handle
42	873801000	Nut, Crownlock #10-24 UNC	90	874930516	Bolt, Hex 5/16-18 x 1
44	532136518	Tube, Pivot, Axle	91	819111416	Washer 11/32 x 7/8 x 16 Gauge
45	532005297	Axle Assembly, Front	92	873680500	Locknut 5/16-18

NOTE: All component dimensions given in U.S. inches.
1 inch = 25.4 mm

REPAIR PARTS

18 HP 50" TRACTOR - - MODEL NO. GT180 (H1850C), PRODUCT NO. 954 00 03-72

MOWER LIFT

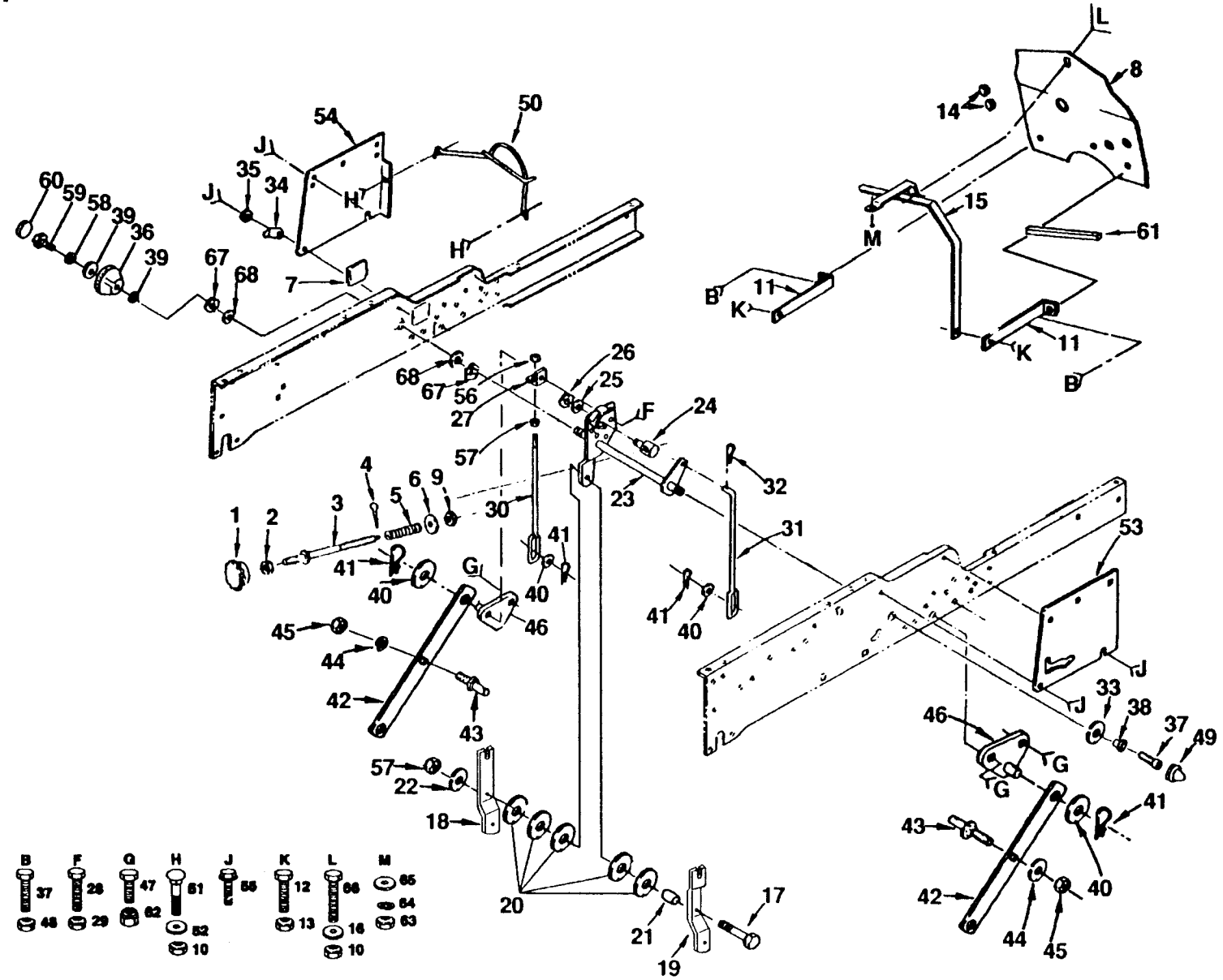

REPAIR PARTS

18 HP 50"TRACTOR - - MODEL NO. GT180 (H1850C), PRODUCT NO. 954 00 03-72

MOWER LIFT

36

KEY NO.	PART NO.	DESCRIPTION	KEY NO.	PART NO.	DESCRIPTION
1	532138057	Handle, Adjust, Lift	35	532120529	Washer, Nylon
2	873350600	Nut, Hex, Jam 3/8-16	36	532123934	Scale, Height Indicator
3	532110811	Rod, Adjust, Lift	37	874760616	Bolt, Hex 3/8-16x1
4	876020308	Pin, Cotter 3/32x3/4	38	532105624	Hub, Lift Shaft
5	532124874	Spring	39	819112410	Washer 11/32x1-1/2x10Gauge
6	819131016	Washer 13/32 x 5/8 x 16 Gauge	40	819171616	Washer 17/32 x 1 x 16 Gauge
7	532121794	Cover, Access	41	532124960	Retainer, Spring
8	532122085	Shield, Head, Read	42	532105429	Arm, Suspension
9	532110807	Nut, Special	43	532105413	Stud, Pivot, Center
10	873680500	Locknut 5/16-18	44	810040800	Washer, Lock 1/2
11	532110903	Brace, Head Shield	45	873220800	Nut, Hex 1/2-13
12	874780408	Bolt, Hex 1/4-20 x 1/2	46	532105501	Bracket, Suspension, Mower
13	873680400	Locknut 1/4-20	47	872140606	Bolt, Carriage 3/8-16x3/4
14	532110436	Grommet	48	873680600	Locknut 3/8-16
15	532128141	Support Assembly, Dash	49	532109412	Cap, Spring
16	819111216	Washer 11/32x3/4x16 Gauge	50	532126651	Guard, Belt, Engine
17	874520628	Bolt 3/8-16x1-3/4	51	872140508	Bolt, Carriage 5/16-18x1
18	532005948	Bracket, Lift, L.H.	52	819111610	Washer 11/32x 1 x 10 Gauge
19	532005947	Bracket, Lift, R.H.	53	532121045	Panel, Dash, R.H.
20	819172410	Washer 17/32x1-1/2x10 Gauge	54	532121046	Panel, Dash, L.H.
21	532005949	Tube	55	817490608	Screw, Hex Wsh. Thdrol 3/8-16x 1/2
22	810040600	Washer, Lock 3/8	56	873800600	Locknut 3/8-16
23	532124217	Shaft, Lift	57	873220600	Nut, Hex 3/8-16
24	532110810	Trunnion, Stop Depth	58	810040500	Washer, Lock Hvy. Helical Spring
25	819151216	Washer 15/32 x 3/4 x 16 Gauge	59	874780516	Bolt, Hex Fin 5/16-18 x 1
26	812000037	Klip Ring	60	532123935	Plug, Hole
27	532007594	Bracket, Lift L.H.	61	532109458	Strip, Foam
28	532007901	Bolt, Shoulder	62	873930600	Nut, Centerlock 3/8-16
29	873900400	Nut, Hex Flange 1/4-20	63	873220400	Nut, Hex 1/4-20
30	532007596	Link, Lift, L.H.	64	810090400	Washer, Lock 1/4
31	532105503	Link, Lift, R.H.	65	819091216	Washer 9/32 x 3/4 x 16 Gauge
32	532124670	Retainer, Spring	66	874760512	Bolt, Hex 5/16-18 x 3/4
33	810040600	Washer, Lock Hvy. Hel. Spring	67	812000022	E-Ring
34	532124763	Pointer, Height Indicator	68	819292016	Washer 29/32 x 1-1/4 x 16 Gauge

NOTE: All component dimensions given in U.S. Inches.
1 inch = 25.4 mm

REPAIR PARTS

18 HP 50" LAWN TRACTOR -- MODEL NO. GT180 (H1850C), PRODUCT NO. 954 00 03-72
MOWER

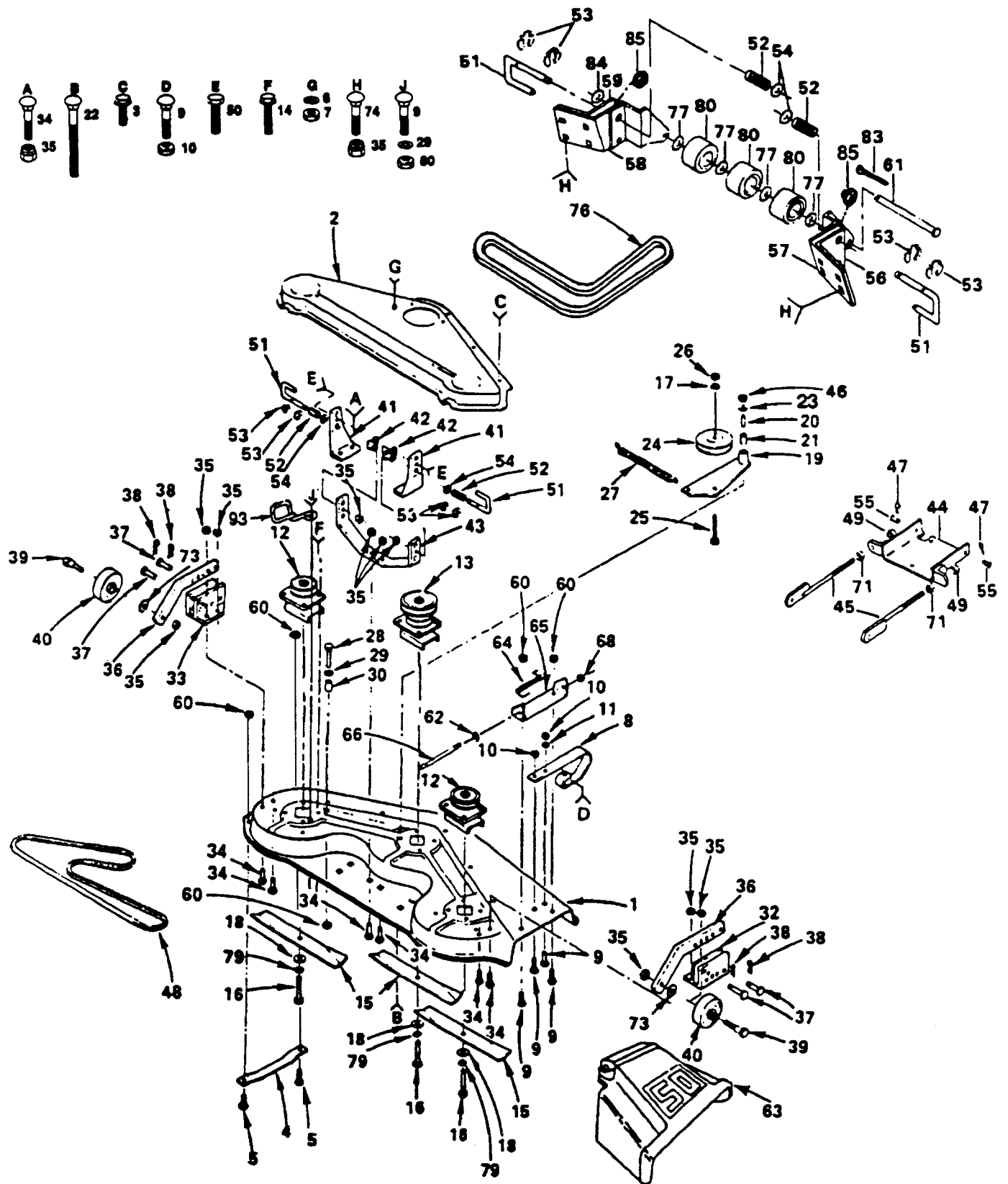

REPAIR PARTS

18 HP 50" LAWN TRACTOR - - MODEL NO. GT180 (H1850C), PRODUCT NO. 954 00 03-72
MOWER

KEY NO.	PART NO.	DESCRIPTION	KEY NO.	PART NO.	DESCRIPTION
1	532121664	Housing, Mower	40	532105455	Wheel, Gauge
2	532121811	Cover, Drive, Deck	41	532105433	Bracket, Suspension
3	817490508	Screw, Hex Washer Thr. Roll 5/16-18 x 1/2	42	532110237	Spacer
4	532125074	Runner, L.H.	43	532105434	Brace, Suspension
5	872110505	Bolt, Carriage 5/16 18 x 5/8	44	532109778	Plate Assembly, Mower Suspension
6	810040500	Washer, Lock 5/16	45	532109771	Bracket, Suspension
7	873220500	Nut, Hex 5/16-18	46	873350500	Nut, Hex 5/16-18
8	532120449	Runner	47	532124660	Clip, Hairpin
9	872140506	Bolt, Carr. 5/16-18 x 3/4	48	532003703	V-Belt
10	532124949	Locknut 5/16-18	49	873680800	Nut, Crownlock 1/2-13
11	819111116	Washer 11/32 x 11/16 x 16 Gauge	50	874760622	Bolt, Hex 3/8-16 x 1-3/8
12	532136819	Mandrel, Secondary	51	532105435	Pin, Release
13	532121617	Mandrel, Primary	52	532003720	Spring
14	817490612	Screw, Hex Washer Thrd. Roll 3/8-16 x 3/4	53	812000039	Ring, Klip
15	532121798	Blade	54	819171612	Washer 17/32 x 1 x 12 Gauge
16	874610624	Bolt, Hex 3/8-24 x 1-1/2 Grade 5	55	532105440	Pin, Clevis
17	810040600	Washer, Lock 3/8	56	532105458	Bracket, Outer, R.H.
18	819132012	Washer 13/32 x 1-1/4 x 12 Gauge	57	532109773	Bracket, Inner, R.H.
19	532124685	Arm Assembly, Idler	58	532110997	Bracket, Inner, L.H.
20	532124702	Liner, Bearing	59	532120000	Bracket, Outer, L.H.
21	532007835	Bearing	60	873680500	Locknut 5/16-18
22	872110522	Bolt, Carriage 5/16 - 18 x 2-3/4	61	532109776	Pin, Pivot
23	819111816	Washer 11/32 x 1-1/8 x 16 Gauge	62	819111016	Washer 11/32 x 5/8 x 16 Gauge
24	532102403	Pulley, Idler	63	532110509	Shield, Deflector
25	874760624	Bolt, Hex 3/8-16 x 1-1/2	64	532106734	Spring, Deflector
26	873220600	Nut, Hex 3/8-16	65	532137607	Bracket, Deflector
27	532104361	Spring	66	532106735	Rod, Hinge
28	874780520	Bolt, Hex 5/16-18 x 1-1/4 Grade 5	68	532110452	Nut, Push
29	819111216	Washer 11/32 x 3/4 x 16 Gauge	71	873220600	Nut, Hex 3/8 x 16
30	532008438	Spacer, Split	73	819171512	Washer 17/32 x 15/16 x 12 Gauge
32	532105448	Bracket, Ga. Wheel, R.H.	74	872240608	Bolt, Carriage 3/8-16 x 1
33	532105449	Bracket, Ga. Wheel, L.H.	76	532110884	V-Belt
34	872240606	Bolt, Carriage 3/8-16 x 3/4	77	819151610	Washer 15/32 x 1 x 10 Gauge
35	873680600	Nut, Crownlock 3/8-16	79	810030600	Washer, Lock 3/8
36	532105453	Bar, Ga. Wheel	80	532109729	Roller, Nose
37	532005565	Pin, Clevis	83	876020412	Pin, Cotter
38	532124670	Retainer, Spring	84	819151616	Washer 15/32 x 1 x 16 Gauge
39	532134249	Bolt, Shoulder	85	532120135	Spacer
			93	532121352	Keeper, Belt L.H.
			—	532127594	Mower Deck, Complete

NOTE: All component dimensions given in U.S. inches.
1 inch = 25.4 mm

REPAIR PARTS

18 HP 50" TRACTOR -- MODEL NO. GT180 (H1850C), PRODUCT NO. 954 00 03-72
TRANSAXLE

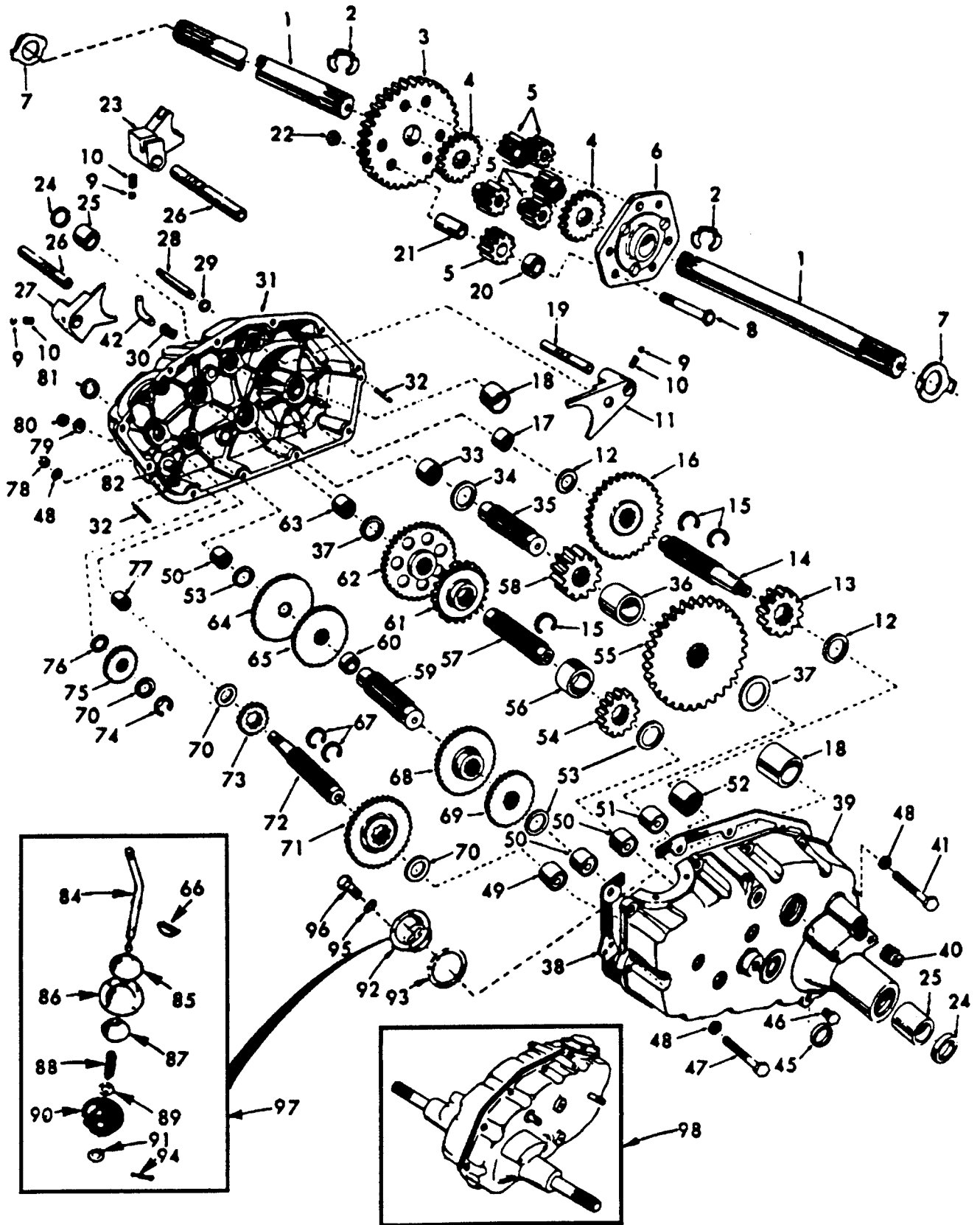

REPAIR PARTS

18 HP 50"TRACTOR - - MODEL NO. GT180 (H1850C), PRODUCT NO. 954 00 03-72

TRANSAXLE

KEY PART NO. NO.	DESCRIPTION	KEY PART NO. NO.	DESCRIPTION
1 4197R	Axle Shaft	51 1529R	Needle Bearing
2 12000034	Retaining Ring	52 8119M	Needle Bearing
3 4199R	Final Drive Gear	53 4220R	Thrust Bearing Race
4 4216R	Differential Gear	54 4209R	3rd Reduction Pinion, Low
5 4215R	Differential Pinion	55 4213R	4th Reduction Gear
6 4217R	Differential Carrier	56 4442R	3rd Reduction Pinion Spacer
7 6256H	Axle Thrust Washer	57 4195R	2nd Reduction Gear Shaft
8 74020652	Bolt, Hex 3/8-24 x 3-1/4 (1" Thread Length)	58 4214R	Final Drive Pinion
9 7392M	Steel Ball	59 4194R	1st Reduction Gear Shaft
10 6272H	Spring Shift Fork Detent	60 7528R	1st Reduction Shaft Spacer
11 4985R	Shift Fork, High-Low Range	61 4208R	3rd Reduction Pinion High
12 6266H	Thrust Bearing Race	62 4207R	2nd Reduction Gear
13 4212R	4th Reduction Pinion	63 7398H	Needle Bearing
14 4196R	3rd Reduction Gear Shaft	64 4203R	Low Speed Gear and 2nd Reduction Pinion Cluster
15 6276H	Snap Ring, Crescent Type	65 4204R	Reverse Gear
16 633A63	High-Low Range Gears	66 2898J	Key, Hi-Pro 1/8 x 17/32
17 8118M	Needle Bearing	67 4926H	Snap Ring, Crescent Type
18 8740H1	Sintered Iron Bearing	68 4205R	Intermediate Speed Gear
19 122238X	Shift Fork Shaft, High-Low Range	69 4206R	High Speed Gear
20 4218R	Differential Pinion Spacer	70 1370H	Thrust Bearing Race
21 6252H1	Differential Pinion Bushing	71 633A69	Intermediate and High Speed Cluster Pinions
22 7810H	Gripco Centerlock Nut 3/8-24	72 208J	Input Shaft
23 6262H	Shift Fork, LH	73 4201R	Low Speed Pinion
24 7393R	Oil Seal	74 12000002	E-Ring
25 992R1	Sintered Iron Bearing	75 1153R	Reverse Idler Gear
26 6216H	Shift Fork Shaft	76 7392H	Reverse Idler Thrust Washer
27 4986R	Shift Fork, RH	77 3990H	Needle Bearing
28 122254X	Shift Shaft, High-Low Range	78 73220500	Nut, Hex 5/16-18
29 6269H	Oil Seal	79 1167R	Sealing Washer
30 5855H	Pressure Relief Valve	80 73360700	Nut, Hex, Jam 7/16-20
31 122162X	Gearcase, Reverse Idler Shaft and Bearings, RH (Includes Key No.'s 17, 18, 25, 33, 50, 63, 76, 77 & 82)	81 6270H	Oil Seal
32 6277H	Dowel Pin	82 7384H	Reverse Idler Shaft
33 4225R	Needle Bearing	84 5384J	Gear Shift Lever, Bent
34 7396H	Thrust Bearing Race	85 2978J	Gear Shift Cap
35 4198R	4th Reduction Gear Shaft	86 633A85	Gear Shift Ball Cover and Pin
36 4200R	4th Reduction Gear Spacer	87 8739H1	Shift Lever Guide Ball, Keyed
37 7395H	Thrust Bearing Race	88 4924H	Spring
38 121878X	Gearcase Gasket	89 19151516	Washer 15/32 x 15/16 x 16 Gauge
39 122163X	Gearcase and Bearings, LH (Includes Key Numbers 18, 25, 49, 50 (2), 51 and 52)	90 110542X	Shift Mechanism Seal
40 13320400	Pipe Plug 1/2-14 N.P.T.	91 19181511	Washer 9/16 x 15/16 x 12 Gauge
41 74780526	Bolt, Hex 5/16-18 UNC x 1-5/8	92 75J	Gear Shift Gate and Reinforcement
42 13170100	Elbow, Street, 90°	93 6274H	Shift Ball Cover Gasket
45 6271H	Oil Seal	94 76020412	Cotter Pin 1/8 x 3/4
46 13060200	Pipe Plug 1/4-18 N.P.T.	95 10040500	Washer, Lock 5/16
47 74780524	Bolt, Hex 5/16-18 x 1-1/2 Grade 5	96 74760514	Bolt, Hex 5/16-18 UNC x 7/8
48 810040500	Washer, Lock, Hvy Helical 5/16	97 633A109	Gear Shift Lever Assembly
49 4895H	Needle Bearing	98 122420X	Transaxle Assembly (Less Brake Drum and Shift Lever)
50 4222R	Needle Bearing		

NOTE: All component dimensions given in U.S. inches
1 inch = 25.4 mm

REPAIR PARTS

18 HP 50" TRACTOR - MODEL NO. GT180 (H1850C), PRODUCT NO. 954 00 03-72

DECALS

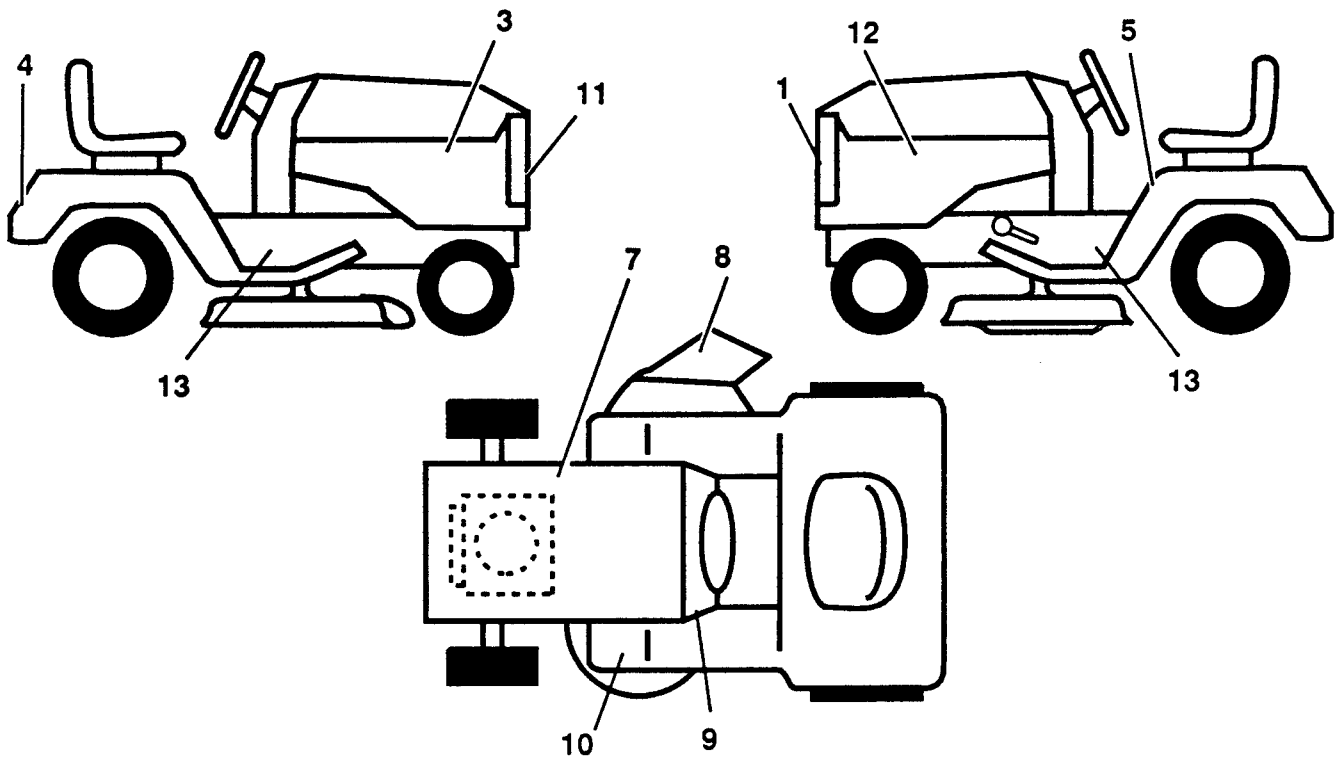

KEY NO.	PART NO.	DESCRIPTION	KEY NO.	PART NO.	DESCRIPTION
1	532125989	Decal, Logo, Grill	9	532136795	Decal, Operating Instructions, (English/French)
3	532137710	Decal, Hood, RH	10	532101892	Decal, Clutch/Brake (English/French)
4	532131582	Decal, Logo, Fender	11	532123246	Decal, Belt Adjustment PTO (English/French)
5	532133795	Decal, Caution, (English/French)	12	532137709	Decal, Hood LH
7	532121549	Decal, Caution, Battery	13	532131589	Decal, Chassis
8	532121349	Decal, Caution, Deflector, (English/French)	--	532131365	Manual, Owner's (English)
			--	532131366	Manual, Owner's French

WHEELS & TIRES

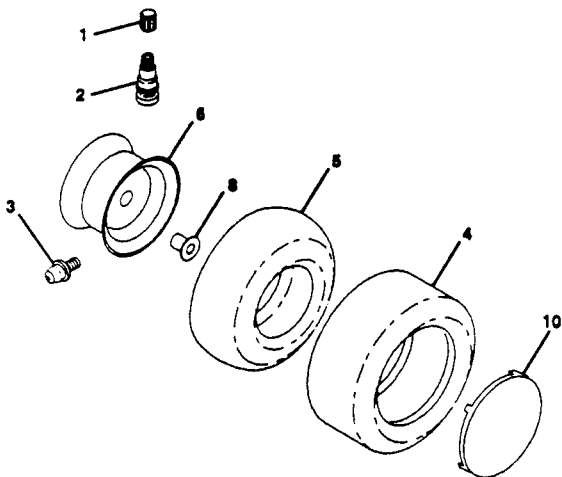

KEY NO.	PART NO.	DESCRIPTION
1	532059192	Cap, Valve
2	532065139	Stem, Valve
3	532124860	Fitting, Grease, Front
3	532124806	Fitting, Grease, Rear
4	532106230	Tire, Front
4	532105588	Tire, Rear
5	532008134	Tube, Front (Optional Service Items Only)
5	532007154	Tube, Rear (Optional Service Items Only)
6	532124864	Rim, Front
6	532124866	Rim, Rear
7	532124578	Cover, Wheel, Front
7	532124579	Cover, Wheel, Rear
8	532124959	Bearing, Flange (Front wheel only)